



COMETGROUP

INVESTOR DAY 2018



MICHAEL KAMMERER

PRESIDENT, PCT

PCT as innovation partner of choice

PCT

The success of Comet PCT is based on extraordinary efforts in close collaboration with the world-leading OEMs

■ % Group sales H1 2018

■ Addressable market (RF power)

■ Current market share

■ PCT

■ Customers

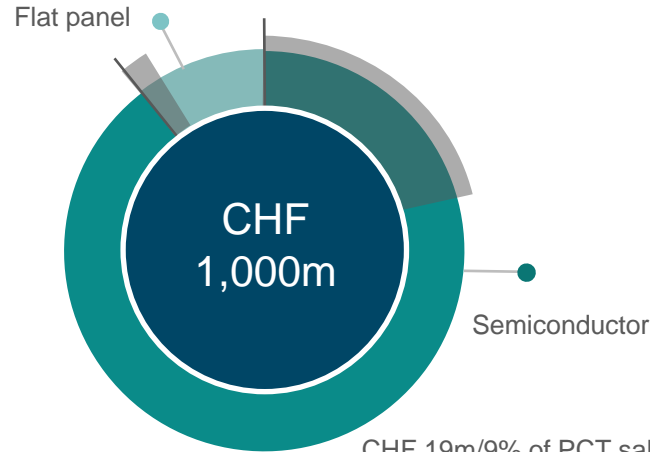
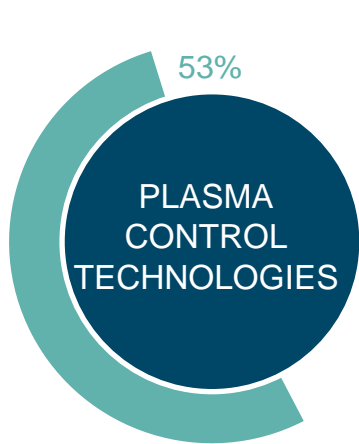

CHF 19m/9% of PCT sales from other markets (niche markets like broadcast, amplifiers etc.)

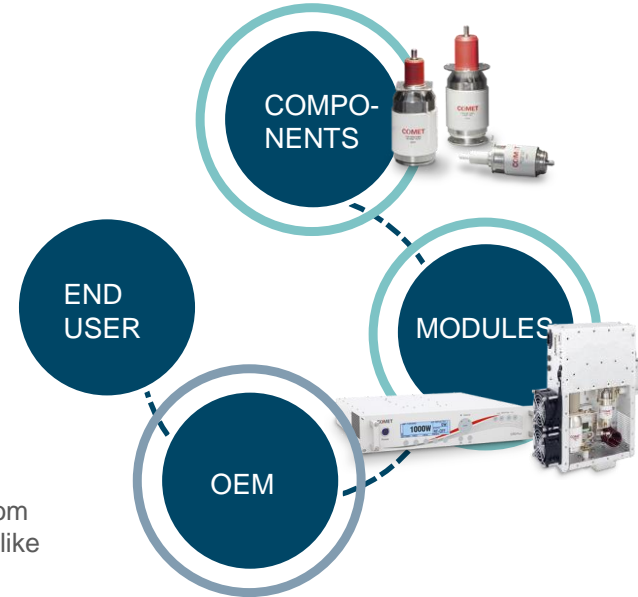



Status Update

2017 – 2020:

Investments Semiconductor Industry

Manage Profitability

Semiconductor cycles are distinctive, but have changed to shorter, self-sustaining cycles on a higher level

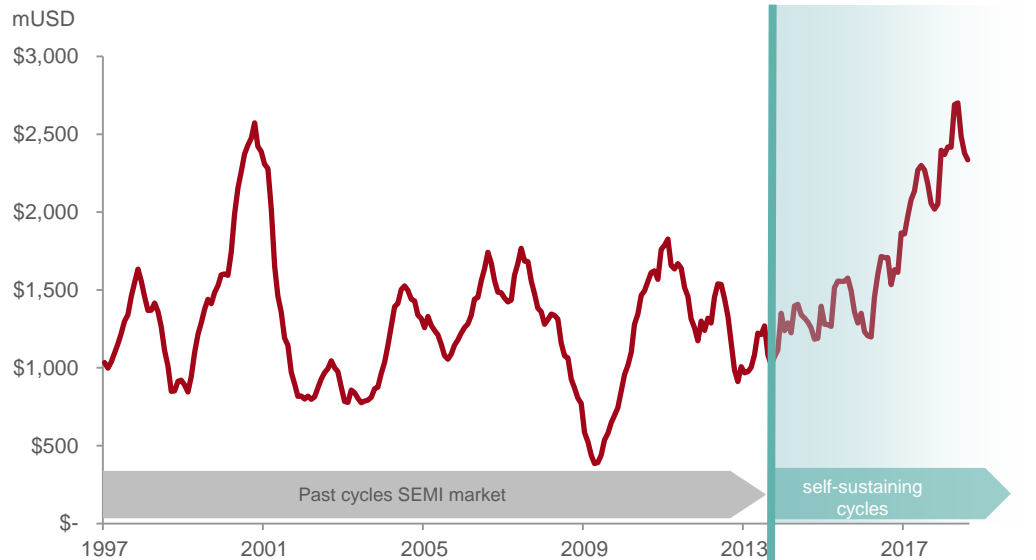

Billings SEMI North America, 3 months average

Change of cycles

- Shorter, self-sustaining
- Remain on a high level

Manage Profitability

Current postponement of fab capex projects caused a slow-down in the semi industry

Comet with flexible cost base to adapt to market



PCT manages the current cycle

Costs:

Reduction of variable costs, e.g. up to 50 % in Flamatt

Operations: Quick wins with lean/Kaizen projects

Be ready for the next ramp

After the ramp of the last three years, PCT is now able to pursue postponed projects

Billings SEMI North America, 3 months average

Global Footprint of Comet PCT

Global footprint gives us flexibility



San José / US
Customer Support, Sales,
Operations, R&D
Employees: ~200



Stolberg / DE
Customer Support, Sales,
Operations, R&D
Employees: ~45

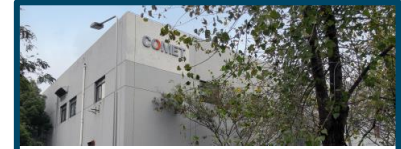

Shanghai / CN
Customer Support, Sales,
Operations
Employees: ~60



Suwon / KR
Customer Support, Sales, R&D
Employees: ~10



Flamatt / CH
Customer Support, Sales,
Operations, R&D
Employees: ~140

Total R&D employees:
97

Growth of data continues

Despite current attenuation in the market,
demand for semiconductors is basically robust

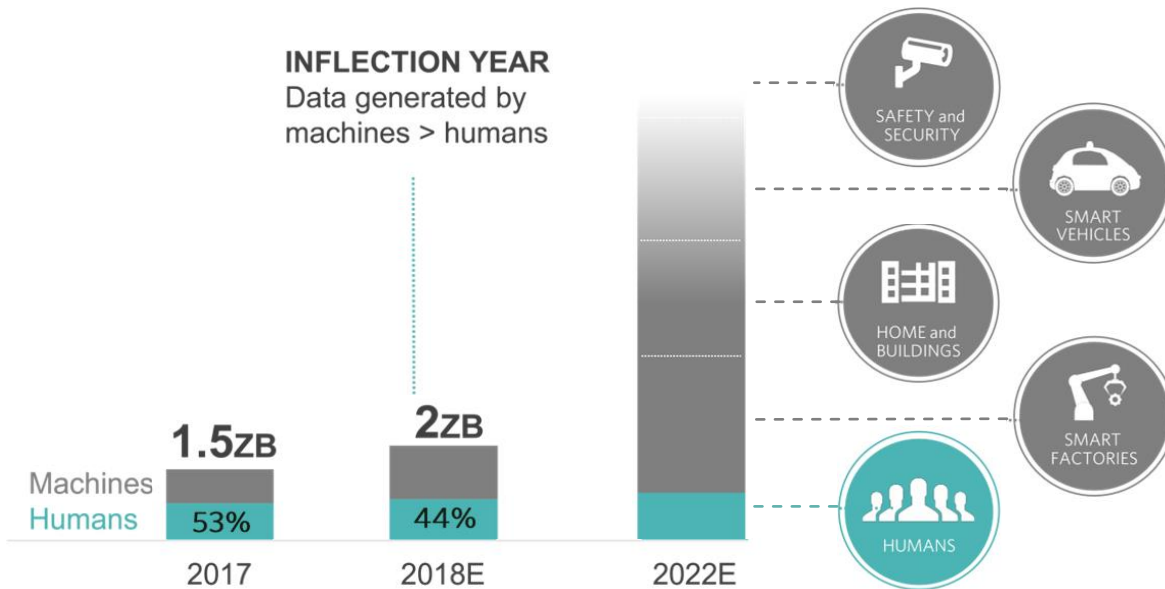

Source: Applied Materials model based on forecasts published by Cisco, Intel, Western Digital

Growth of data continues

Data Generation

IoT and Industry 4.0 driving
an explosion of data

Data Storage

More data needs to be processed and stored
than ever before – **Storage alone is not
sufficient or economical**

Compute

New compute models to turn
data into \$\$\$
New compute architectures to process
data at the edge and in the cloud

Growth of data continues

Despite current attenuation in the market,
demand for semiconductor is basically robust

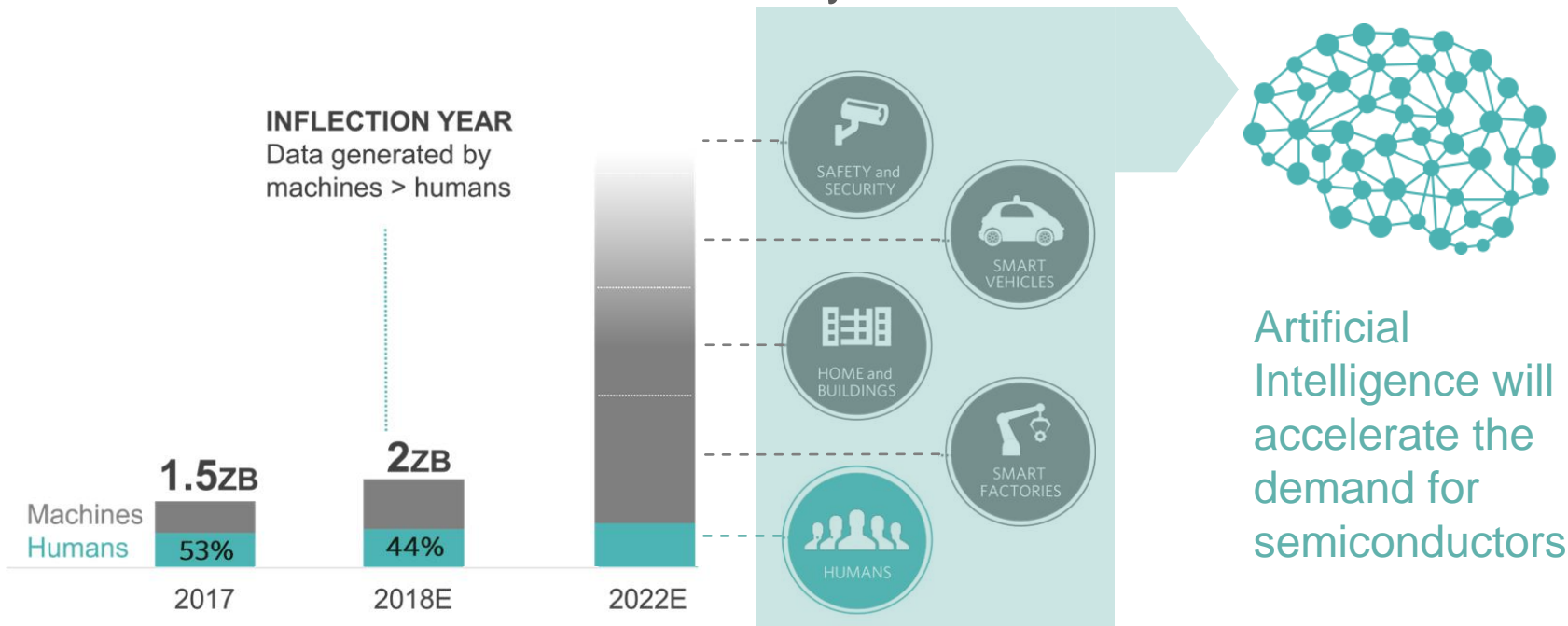

Source: Applied Materials model based on forecasts published by Cisco, Intel, Western Digital

Global Fab Forecast 2017 – 2020

Investments in fab technology, product upgrades and additional capacity will grow as numerous new fabs will boost equipment demand.

SEMI World Fab Forecast report, August 2018

USD 220 bn from 2017 – 2020 Investment Potential of New Fabs and Lines

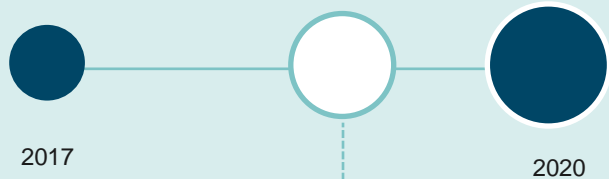

- Robust outlook for 2019
- 4th consecutive year of growth
- Highest investment year ever

Global Fab Forecast 2017 – 2020 / Equipment in USD bn

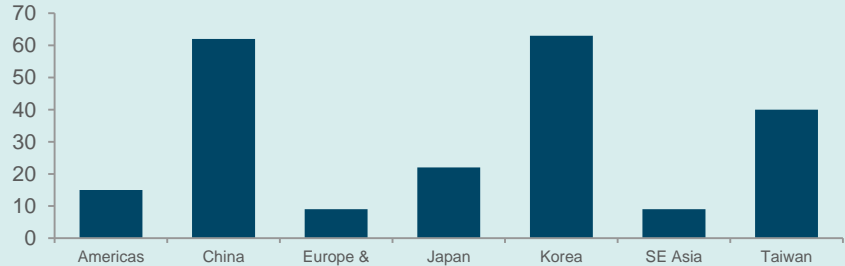

Source: World Fab Forecast report, Aug. 2018, SEMI

78

fabs/lines are known having started or will start construction between 2017 to 2020

19

began construction in 2017/18

59

are expected to begin in 2019/20

1 - 1.5

years is typical time required to equip a new fab

How does PCT participate in these investments?

Growing with the market leaders

The main driver is the rise in vacuum processing steps. Most of those deposition and etch processes require a plasma energy source, what results in increasing demand for tools with power subsystems such as RF power generators and matching networks.

Power subsystems grew at more than 20 % CAGR between 2013 and 2018

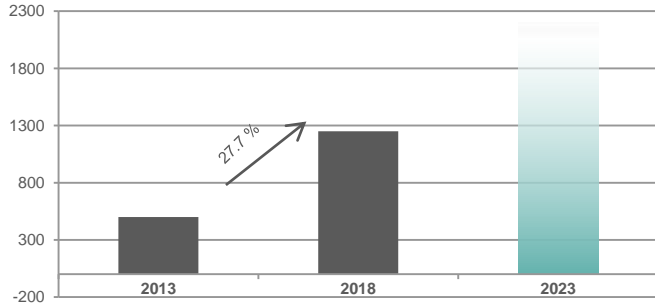

Source: VLSI

60 % of power subsystems go to etch tools

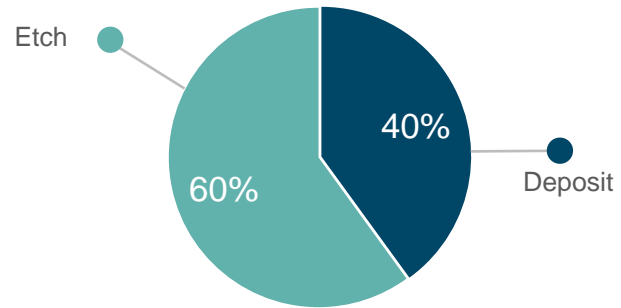

From 2D to 3D NAND

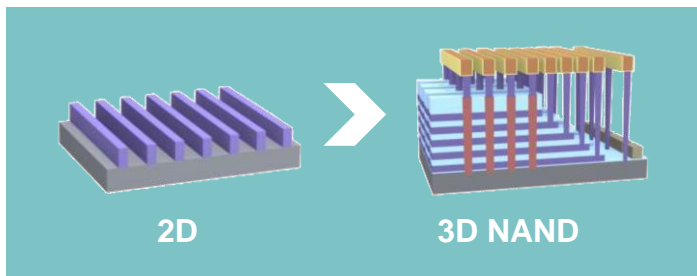

Multiple patterning and 3D NAND high-volume manufacturing have significantly increased the number of deposition and etch processing steps.

3D NAND: longer and more difficult etch processes are requiring a **wider range of power solutions.**

➔ **140 layer 3D NAND will become a reality by 2021**

➔ **Opportunity: Technology will spur the demand for tools**

➔ **Challenges rise with number of layers**

	Layers	Pair Thickness (nm)
2015	32 / 36	~70
2016	48	~62
2017	64 / 72	~60
2018	>90	~55
2020	>120	~50
2021	>140	45-50

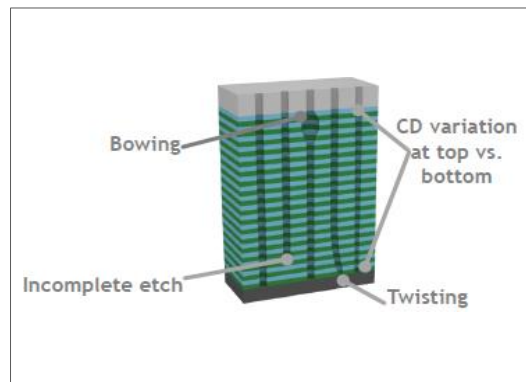

Source Graphics: Applied Materials / Lam Research



Set to fulfill market requirements

Focus

Set to fulfill market requirements

Full RF power subsystems from one source



RF GENERATOR

MATCH

PLASMA

Complete RF product portfolio

- Main power subsystems: generators and power matching networks
- Digitalization of products
- Complete portfolio in HF/MF/LF

Challenges

- Offer a competitive product portfolio to be considered as attractive alternative to the existing RF suppliers
- Comet competes with technology which has been developed and improved for several decades
- Major drivers for product selection are technical superiority and cost

Set to fulfill market requirements

Today, PCT is well positioned to succeed as a strategic partner and preferred supplier for impedance matching networks

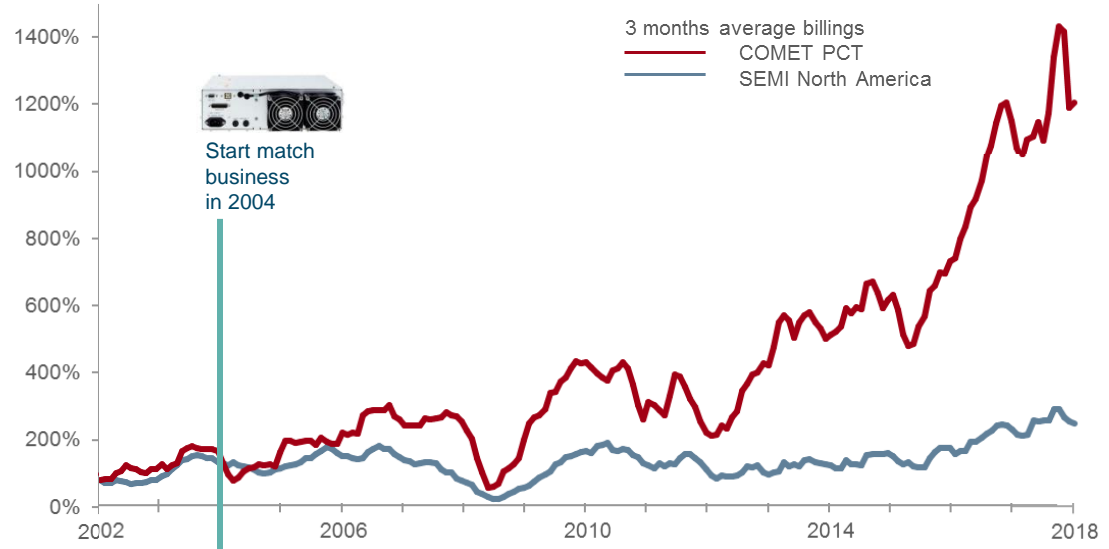

PCT has been out-growing the RF power supply market since 2006 and is confident to also meet future requirements

Set to fulfill market requirements

Competitive landscape in RF Power subsystems

Comet already #3 even without generator business

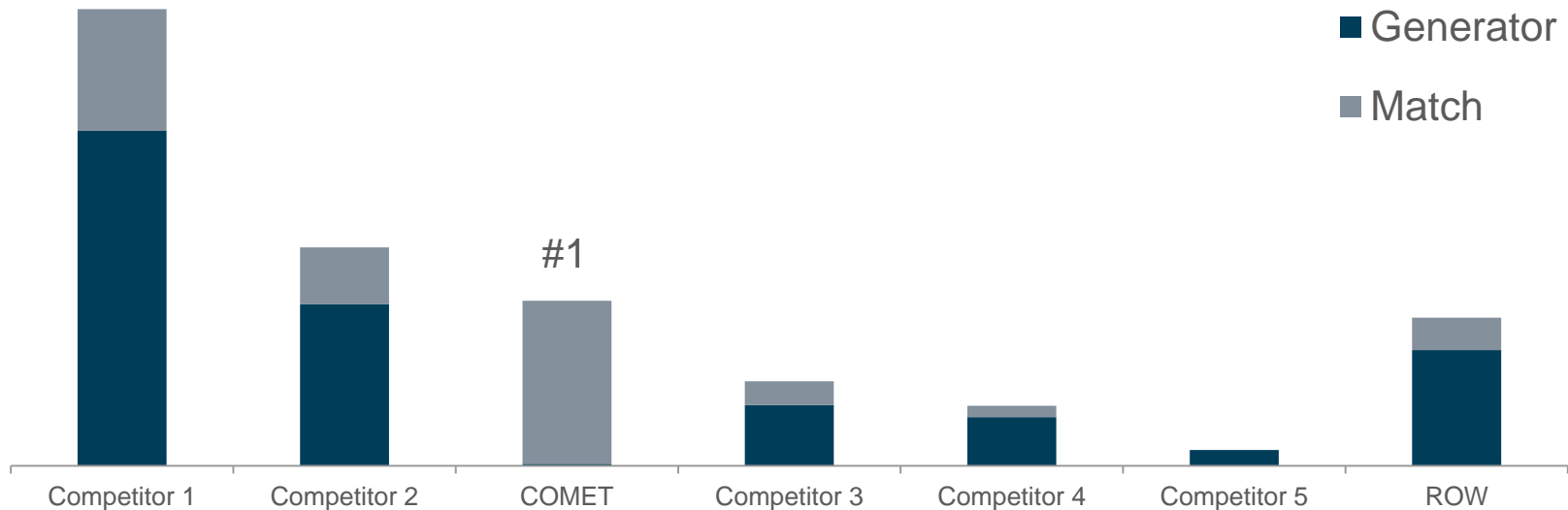

Source: Revenue 2016, VLSI Report April 2017



ANDRE GREDE

VP GLOBAL R&D, PCT

New RF platform for further growth

PCT as innovation partner of choice

How our technology drives our customers success

- Semiconductors are the basis of all electronic devices - not only consumer products but also automotive, aviation, communication and information
- Our customers are 100% technology driven to enable next generation

- processors and memory
- displays and solar cells
- smart sensors & detectors
- solid state batteries

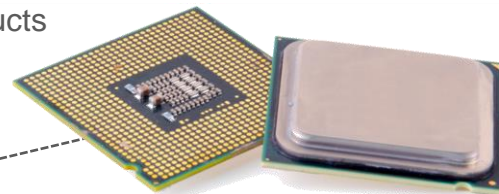

- Manufacturing of semiconductors is a highly complex process
- The most critical part is building the semiconductors in an RF plasma on a silicon wafer
- COMET cutting edge products generate and control the high frequency power needed to ignite and run the plasma process
- Our leading position in Vacuum Capacitors and RF Machboxes makes us one of the most critical players in SEMI

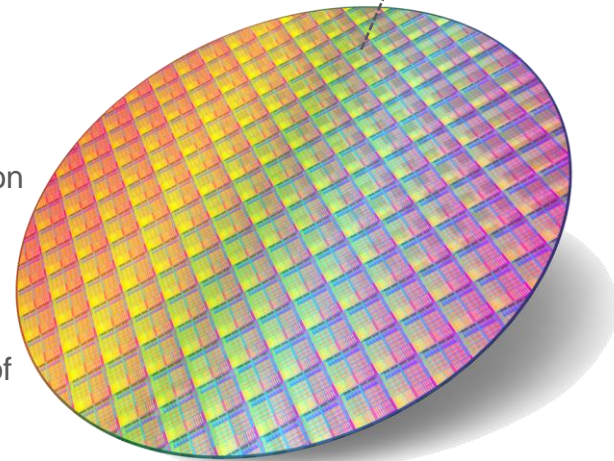

PCT as innovation partner of choice

How our products help to produce semiconductors

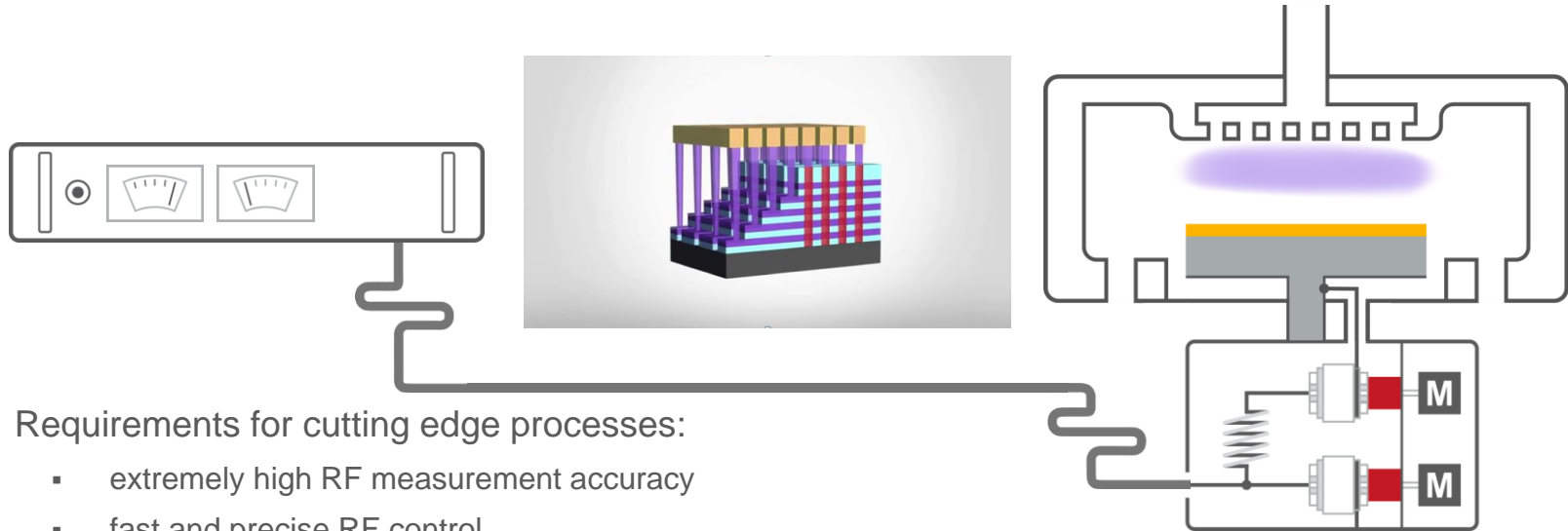

Requirements for cutting edge processes:

- extremely high RF measurement accuracy
- fast and precise RF control
- superior repeatability over a long time
- outstanding quality, zero failure tolerance

Source (video): LAM

PCT as innovation partner of choice

Interconnected RF System to solve future challenges

Future processes in SEMI will require:

- advanced RF control systems
- higher measurement accuracy
- increased repeatability



highspeed digital interface

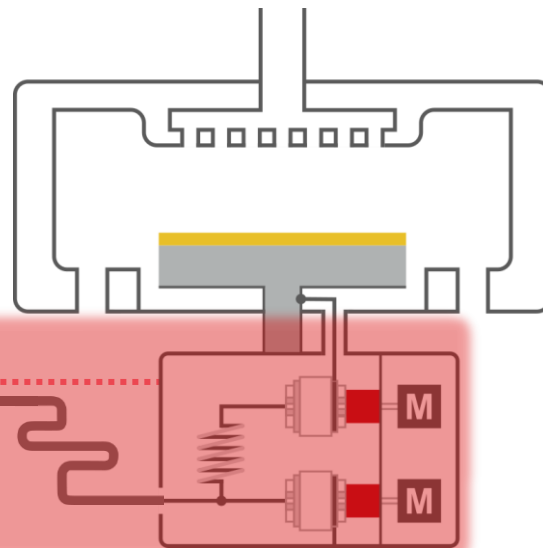

Integrated RF systems from COMET will offer:

- Data driven process analysis and optimization
- New features for advanced RF plasma process control
- Flexible and quickly customizable RF solutions

COMET`s path to technology leadership in SEMI

Only company worldwide offering all 3 technologies

- To solve future technology and cost challenges in RF for SEMI
- To build fully customized RF power delivery systems

Investing in digitalization of products and R&D environment

- Enabling future applications with intelligent, data driven products
- Allowing faster development cycles and on-site system upgrades
- Providing new functionalities and the benefits of fully interconnected RF systems

With a global team of outstanding experts

- Earned the trust and support of our customers
- Available in the US, Europe and Asia for worldwide support



Completing our technology and product portfolio will move our position
from an important to a unique supplier of RF equipment in SEMI



Why Comet as innovation partner of choice?

Unique Elements for Success

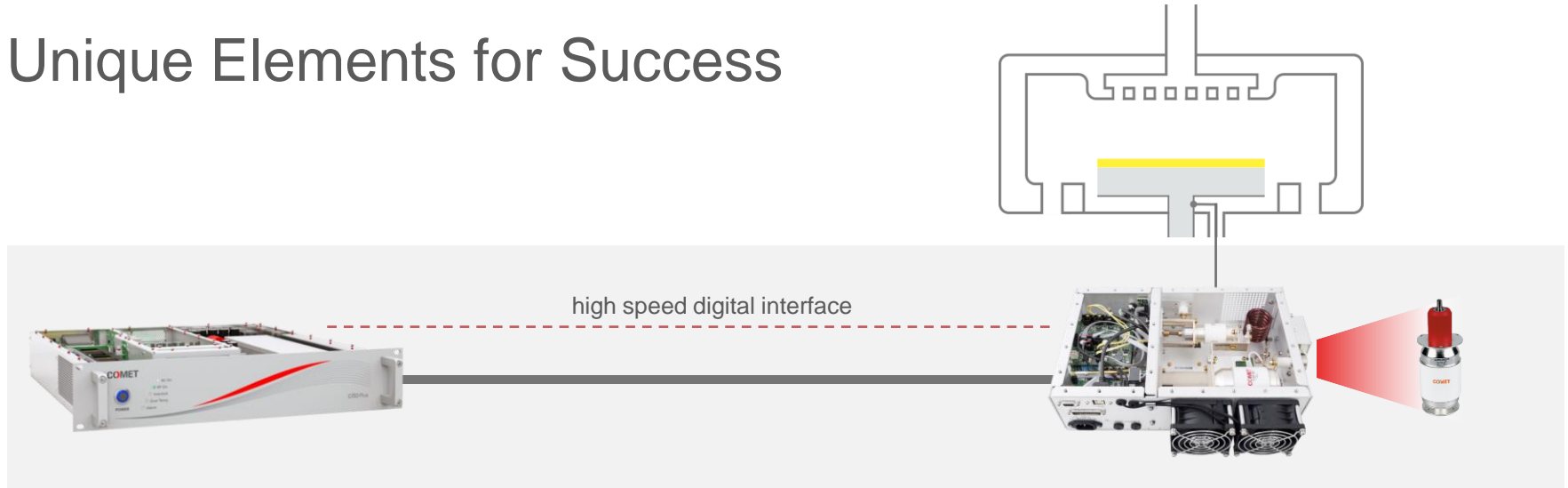

- Comet is the only company worldwide offering all three RF power technologies
- Comet is developing a unique, fully digitalized modular platform
- Comet has built a global team of outstanding experts



Thank you for your interest